

Clarke®

WOODWORKER



195MM BENCH TOP BANDSAW

MODEL NO: CBS205

PART NO: 6460072

OPERATION & MAINTENANCE INSTRUCTIONS

UK
CA | CE



ORIGINAL INSTRUCTIONS

DL1221 ISS 2

INTRODUCTION

Thank you for purchasing this CLARKE 8" (195mm) Bench Top Bandsaw.

Before attempting to operate the machine, it is essential that you read this manual thoroughly and carefully follow all instructions given. In doing so you will ensure the safety of yourself and that of others around you, and you can also look forward to the product giving you long and satisfactory service.

GUARANTEE

This CLARKE product is guaranteed against faulty manufacture for a period of 12 months from the date of purchase. Please keep your receipt as proof of purchase.

This guarantee is invalid if the product is found to have been abused or tampered with in any way, or not used for the purpose for which it was intended.

Faulty goods should be returned to their place of purchase, no product can be returned to us without prior permission.

This guarantee does not effect your statutory rights.

ENVIRONMENTAL PROTECTION

Recycle unwanted materials instead of disposing of them as waste. All unwanted accessories and packaging should be sorted and taken to a recycling centre for disposal in a manner which is compatible with the environment.

ENVIRONMENTAL RECYCLING POLICY



Through purchase of this product, the customer is taking on the obligation to deal with the WEEE in accordance with the WEEE regulations in relation to the treatment, recycling & recovery and environmentally sound disposal of the WEEE.

In effect, this means that this product must not be disposed of with general household waste but according to the laws governing Waste Electrical and Electronic Equipment (WEEE) at a recognised disposal facility.

SAFETY WARNINGS



CAUTION: FAILURE TO FOLLOW THESE PRECAUTIONS COULD RESULT IN PERSONAL INJURY, AND/OR DAMAGE TO PROPERTY.

WORK ENVIRONMENT

1. Keep the work area clean and well lit. Cluttered and dark areas invite accidents.
2. DO NOT operate power tools in explosive atmospheres, such as in the presence of flammable liquids, gases or dust. Power tools create sparks which may ignite the dust or fumes.
3. Keep children and bystanders away while operating a power tool. Anyone entering the work area must wear personal protective equipment. Distractions can cause you to lose control and fragments of work or a broken blade may fly away and cause injury.
4. Store power tools properly when not in use. Abrasive products should be stored in a dry, secure place out of the reach of children.
5. Please read these instructions carefully and retain for future reference.

ELECTRICAL SAFETY

1. Power tool plugs must match the outlet. NEVER modify the plug in any way. DO NOT use adapter plugs with earthed (grounded) power tools. Unmodified plugs and matching outlets will reduce the risk of electric shock.
2. DO NOT expose power tools to rain or wet conditions. Water entering a power tool will increase the risk of electric shock.
3. DO NOT abuse the cable. NEVER use the cable for carrying, pulling or unplugging the power tool. Keep the cable away from heat, oil, sharp edges or moving parts. Damaged or entangled cables increase the risk of electric shock.
4. Position the power cable so that it cannot be inadvertently pulled or pinched and where it does not cause a trip hazard.
5. Never use the machine if the electric cable or plug is in poor condition.
6. This machine is designed for indoor environments and must not be used for other purposes.

7. If the machine requires repair, always contact your CLARKE dealer. Always insist on original spare parts. Repairs carried out by unauthorized persons may be dangerous and invalidate the guarantee.
8. Before cleaning or maintenance operations, always unplug the machine from the power supply.

PERSONAL SAFETY

1. Stay alert, watch what you are doing and use common sense when operating a power tool. DO NOT use a power tool while you are tired or under the influence of drugs, alcohol or medication. A moment of inattention while operating power tools may result in personal injury.
2. Use personal protective equipment. Always wear eye protection. Safety equipment such as dust mask, non-skid safety shoes, hearing protection and a workshop apron capable of stopping small abrasive or workpiece fragments.
3. Avoid accidental starting. Ensure the switch is in the off position before plugging in. Plugging in power tools that have the switch on invites accidents.
4. Remove any adjusting key or wrench before turning the power tool on. A wrench or a key left attached to a rotating part of the power tool may result in personal injury.
5. DO NOT overreach. Keep proper footing and balance at all times. This enables better control of the power tool in unexpected situations. Dress properly. Do not wear loose clothing or jewellery.
6. Keep your hair, clothing and gloves away from moving parts. Loose clothes, jewellery or long hair can be caught in moving parts. Keep the work area clean and tidy.
7. Avoid operator fatigue. Stop the power tool at regular intervals for a short break to rest hands and arms.
8. Maintain your tools. Keep all working surfaces dry and clean.

POWER TOOL USE AND CARE

1. DO NOT force the machine. Use the correct power tool for your application. It will do a better and safer job at the rate for which it was designed.
2. DO NOT use the power tool if the switch does not turn it on and off. Any power tool that cannot be controlled with the switch is dangerous and must be repaired.
3. Disconnect the power tool from the power supply before making any adjustments, changing accessories, or storing the tool. These measures will reduce the risk of the power tool starting accidentally.

4. Store power tools out of the reach of children and do not allow persons unfamiliar with these instructions to operate the power tool. Power tools are potentially dangerous in the hands of untrained users.
5. Maintain power tools in top condition. Keep tools/ machines clean for the best and safest performance. Check for misalignment or binding of moving parts, broken parts, or any condition that may affect the power tool's operation. If damaged, have the power tool repaired before use. Many accidents are caused by poorly maintained power tools.
6. Use recommended accessories. The use of improper accessories could be hazardous.
7. Machine cleanliness. DO NOT allow the ventilation slots in the machine to become blocked with dust. Regularly clean the power tool's air vents. The motor fan will draw dust inside the housing and accumulation of material could cause electrical hazards.
8. Check the power tool for damage before using the machine. Any damaged part should be inspected to ensure that it will operate properly and perform its intended function. Check for alignment of moving parts, breakage of parts, mountings, and any other condition that may affect the machine's operation. Any damage should be properly repaired or the part replaced. If in doubt, DO NOT use the machine. Consult your local CLARKE dealer.

SERVICING

1. When necessary, have your power tools serviced or repaired by a qualified person using identical replacement parts. This will ensure that the safety of the power tool is maintained.







ADDITIONAL PRECAUTIONS FOR BANDSAWS

1. ALWAYS check safety guards are in place and functioning correctly before switching the machine on.
2. ALWAYS use a push stick & fence for small workpieces wherever practical.
3. ALWAYS use the appropriate saw blade for the material being cut.
4. NEVER touch the blade immediately after use, when changing the blade always allow time for it to cool.
5. NEVER use damaged blades. (Replacement blades are available from your CLARKE dealer).
6. NEVER attempt any maintenance or adjustments of the saw band when it is in motion.
7. DO NOT remove jammed cut off pieces until the blade has stopped.
8. Replace the table insert if the slot has become enlarged.

9. When cutting wood, ensure any nails or fastenings have been removed beforehand. Nails will damage the saw blade.
10. When cutting round timber stock, use a suitable jig or fixture to keep the work from turning.
11. Always ensure the blade is fully tightened and correctly adjusted before use.
12. Keep the mains cable well away from the working parts of the machine and ensure an adequate electrical supply is close at hand so that the operation is not restricted by the length of the cable.
13. Switch the machine off as soon as the task is completed.

SAFETY SYMBOLS

The following safety symbols may be found on the machine.

	Read the manual and safety instructions before use		Eye protection should be worn
	Ear protection should be worn		Dust mask should be worn
	HAZARD, Motor gets hot		Disconnect from power source before maintenance or repair
	HAZARD, Sharp Blade		

SPECIFICATIONS

	CBS205
Weight	16.9 kg
Dimensions (W x D x H)	391 x 455 x 681 mm
Table Size (W x D)	302 x 304 mm
Throat Width	195 mm
Table Tilt Angle	90 - 45°
Maximum Cutting Depth @ 90°	80 mm
Maximum Cutting Depth @ 45°	45 mm
Height of Fence	52 mm
Power supply	230V - 50Hz
Rated Input Wattage @230V	250 W
Motor speed	1487 rpm
Blade Speeds	15.83 m/sec
Duty Cycle	S2
Sound Pressure Level (Lp)	82.6 dB(A)
Sound Power Level Measured (Lw)	93.6 dB(A)
Blade dimensions	
Blade Length (welded loop)	1400 mm
Blade Width	6.35 mm
Blade Tooth Pitch	6 tpi
Blade thickness	0.8 mm

ELECTRICAL CONNECTIONS



WARNING! Read these electrical safety instructions thoroughly before connecting the product to the mains supply.

Before switching the product on, make sure that the voltage of your electricity supply is the same as that indicated on the rating plate. This product is designed to operate on 230VAC 50Hz. Connecting it to any other power source may cause damage.

This product may be fitted with a non-rewireable plug. If it is necessary to change the fuse in the plug, the fuse cover must be refitted. If the fuse cover becomes lost or damaged, the plug must not be used until a suitable replacement is obtained.

If the plug has to be changed because it is not suitable for your socket, or due to damage, it should be cut off and a replacement fitted, following the wiring instructions shown below. The old plug must be disposed of safely, as insertion into a mains socket could cause an electrical hazard.

If the colours of the wires in the power cable of this product do not correspond with the markings on the terminals of your plug, proceed as follows.

- The **Blue** wire must be connected to the terminal marked **N** or coloured **Black**.
- The **Brown** wire must be connected to the terminal marked **L** or coloured **Red**.
- The **Yellow and Green wire** must be connected to the terminal marked **E** or coloured **Green**.

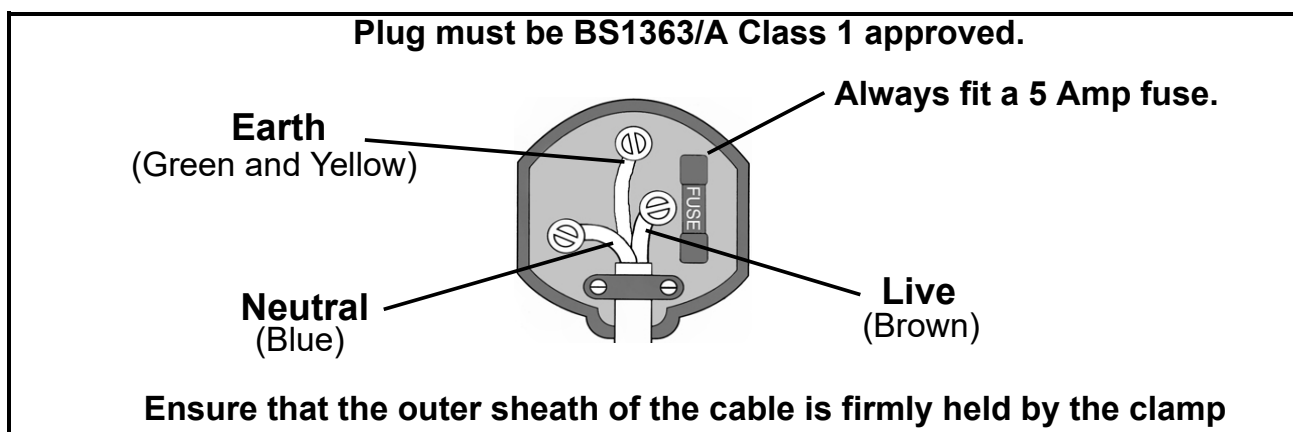

It is strongly recommend that this machine is connected to the mains supply via a Residual Current Device (RCD)

If in any doubt, consult a qualified electrician. DO NOT attempt any repairs yourself.

OVERVIEW & CONTENTS

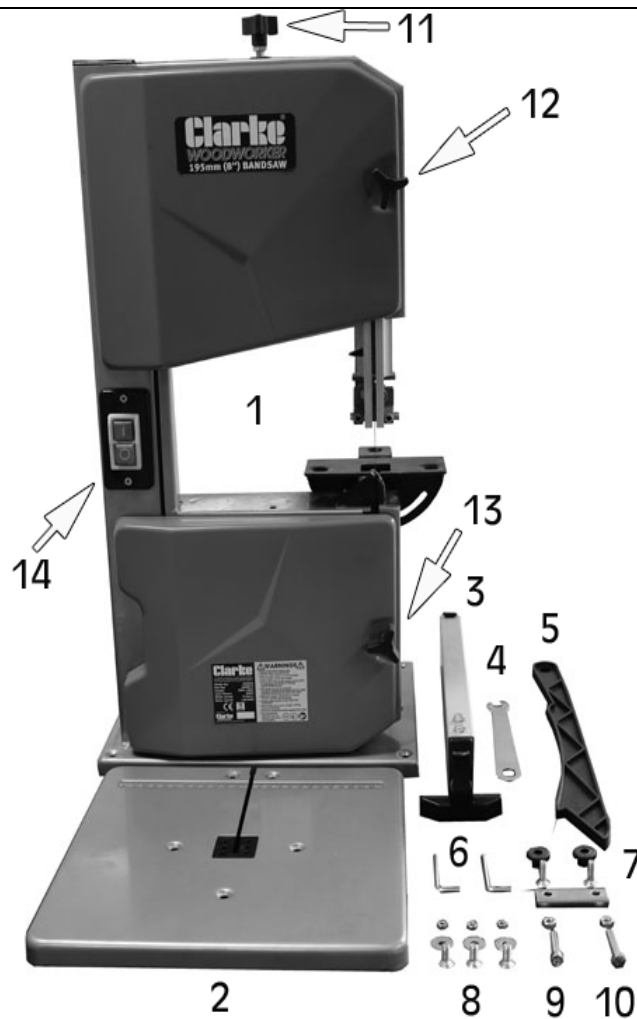

No	DESCRIPTION
1	Bandsaw Assembly
2	Table
3	Parallel Rip Fence Assembly
4	Spanner
5	Push Stick
6	Allen Keys (3mm & 5mm)
7	U Shaped Blocker c/w Nuts (M6) & Bolts

No	DESCRIPTION
8	Table Nuts (M6), Bolts & Washers
9	Push Stick Hook/Nut & Bolt (M6)
10	Table Stop Bolt & Lock Nut (M6)
11	Blade tension Setting Knob
12	Upper Cover Release Knob
13	Lower Cover Release Knob
14	Start/Stop Buttons

Make sure that all parts are un-damaged and are present. If any parts are missing or damaged please contact your CLARKE dealer immediately.

ASSEMBLY

PREPARATION

For maximum stability the bandsaw should be bolted firmly to either a workbench, a suitable stand, or a piece of plywood, 5/8" (15.9mm) thick, and the plywood should be clamped firmly to a workbench whenever the bandsaw is being used.

The saw must be located in an area large enough to allow you to work freely, taking into account the likely size of your workpiece, ensuring adequate lighting.

Make sure also that an adequate electrical supply is close by. Take extra care if extension leads are used. Make sure that there is no possibility of tripping over the lead when moving around the work area.

FITTING THE TABLE

1. Place the bandsaw on a flat level surface
2. Remove the U Shaped Blocker from the table (if fitted).
3. Fit the table to the bandsaw using 3mm allen key x 3 nuts and bolts and 18mm flat washers (A,B & C). Ensure the saw blade is central in the table slot.
4. Screw the table stop bolt into the underneath of the table (See page 11).
5. Re-fit the U Shaped Blocker to the table.
6. Hang the push stick and spanner on the hook/nut on the side of the machine for safe keeping.
7. Fit the rip fence to the table if required.

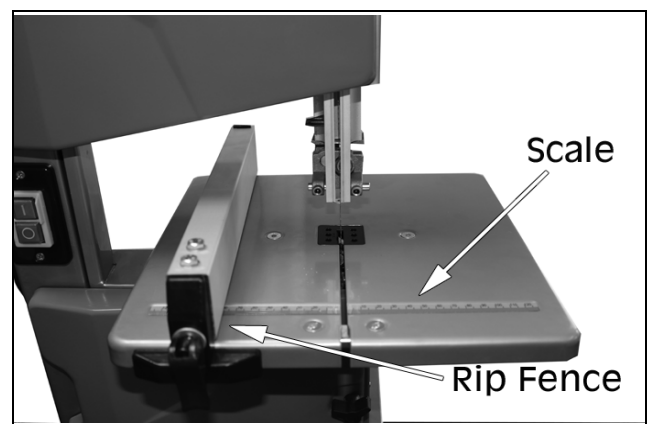
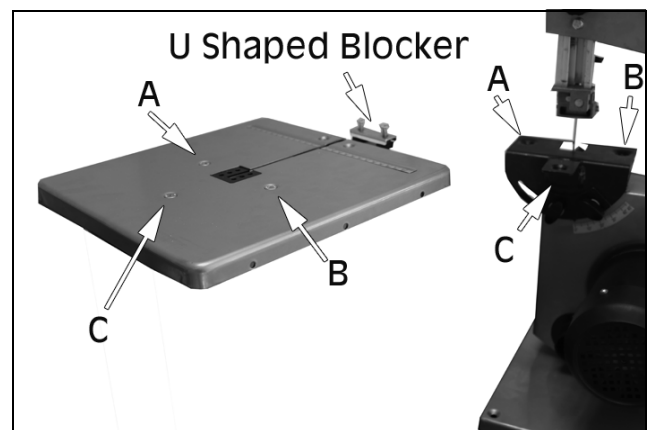

ADJUSTING THE COMPONENTS

TILTING THE TABLE

1. Loosen the table tilt knobs and adjust the table to the desired angle.
2. Use the angle indicator scale on the table tilting bracket, to find the desired angle.
3. Re-tighten the table tilt knobs to secure the table. For assured accuracy, we recommend checking the tilt angle using a set square.
4. With the table exactly level, it should rest on the stop bolt shown. Adjust the height of the bolt by screwing it in or out of the table and securing with the locknut. Check with a set square that the table is exactly level when resting on the stop bolt.

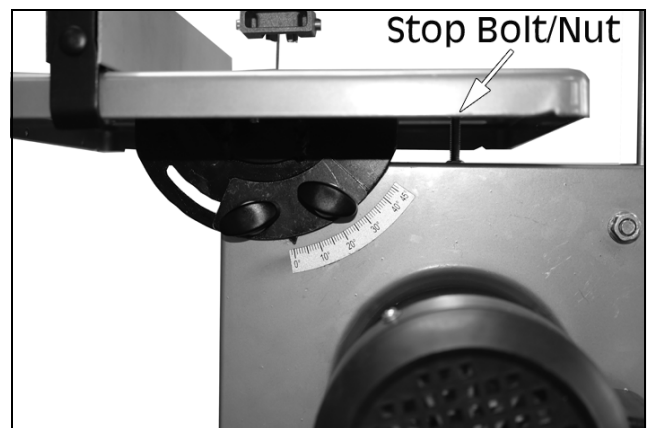
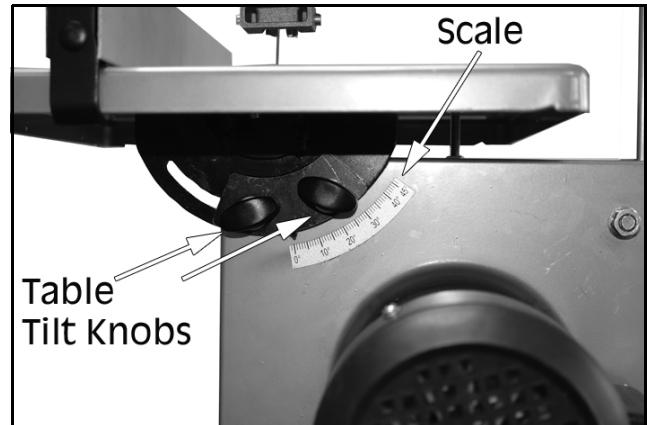

TRACKING THE SAW BLADE

1. Open the upper and lower covers by releasing the cover knobs on the front of the machine.
 - The panels will not open unless the twist knobs are first released.
2. Manually rotate the upper wheel, taking care of the sharp blade.

If the saw blade does not run on the centre of the rubber tyre, the tracking needs to be corrected before use by adjusting the tilt angle of the upper bandsaw wheel.

3. Turn the blade tracking knob clockwise or anticlockwise until the saw blade tracks centrally on the rubber tyre of both wheels.

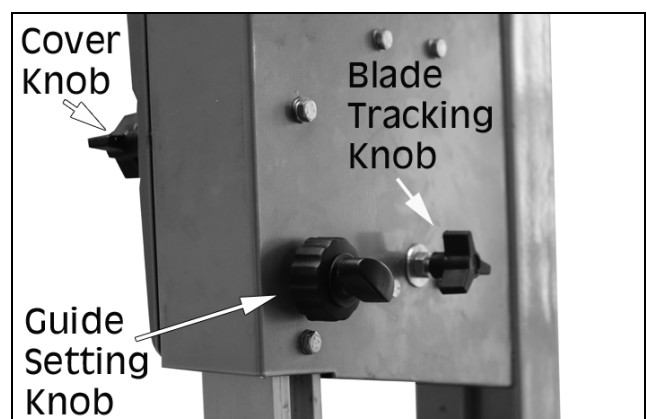

4. After adjusting, close both covers.

ADJUSTING THE BLADE TENSION



CAUTION: TOO MUCH TENSION CAN CAUSE THE SAW BLADE TO BREAK. TOO LITTLE TENSION CAN CAUSE THE BLADE TO MAKE IRREGULAR (WANEY) CUTS.

1. ALWAYS make sure the machine is unplugged from the power supply
2. Raise the upper blade guide fully by twisting the blade guide setting knob.
3. Check the tension by pressing with a finger against the side of the blade, halfway between the table and upper guide.
 - The blade should not flex sideways by more than 2 mm at its longest span.
4. Turn the blade tension knob to adjust the tension.
 - Turning the blade tension knob clockwise will increase the blade tension.

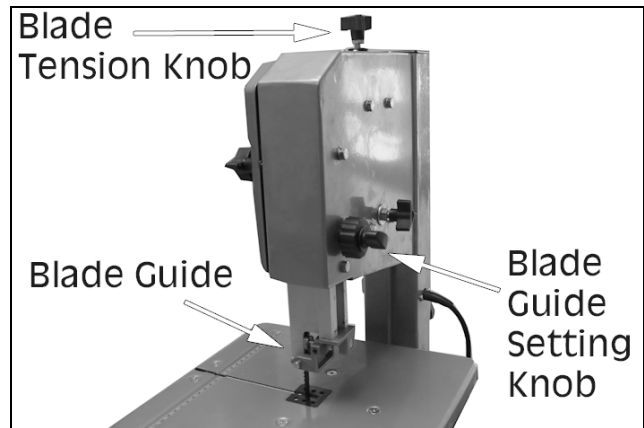

BLADE GUIDES / BEARING SETTING

The upper and lower blade guides need to be re-adjusted after any blade change or tracking adjustment.

1. Loosen the set-screws (A) and position the guide pins 0.5 mm from the blade. Tighten the set screws.
2. Loosen the socket-headed bolt (B) and adjust guide pin carrier position, so that guide pins are positioned 1- 2mm from teeth of blade. Retighten the socket-headed bolt (B).
3. Repeat the process with the lower blade guide located in the lower section of the bandsaw.
 - Note that the lower guide assembly is identical but installed upside-down, and that access to the socket-headed bolt (B) is through the holes provided.

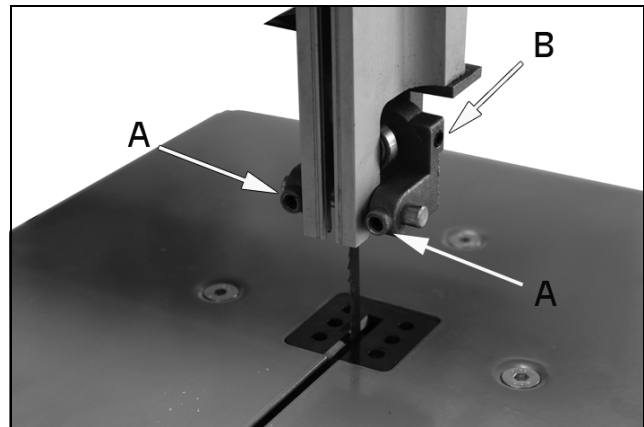

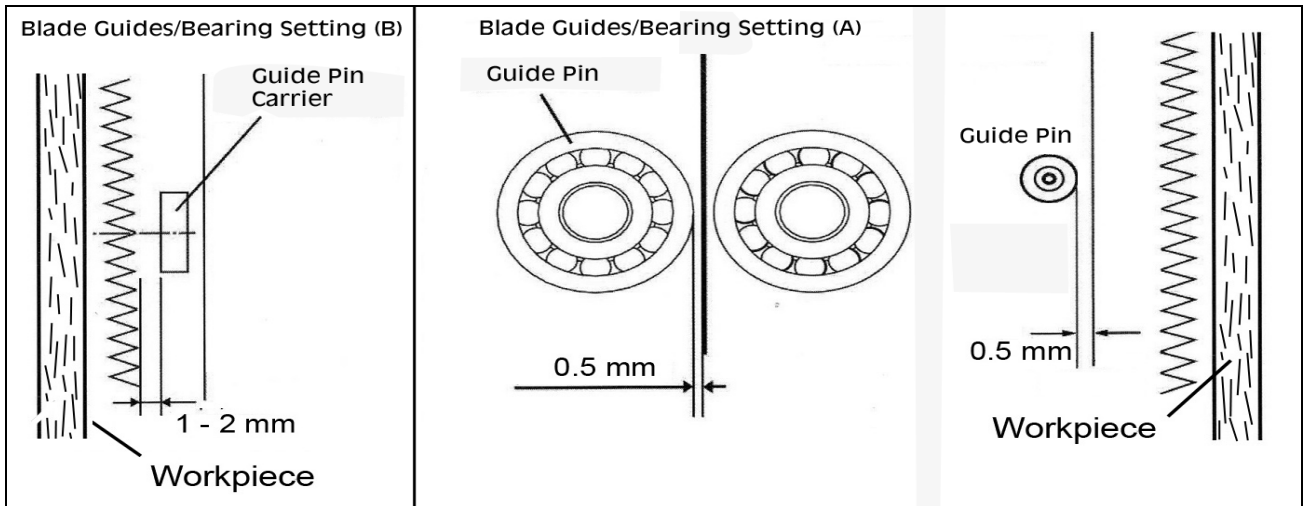

UPPER BLADE GUIDE ADJUSTMENT

The height of the upper blade guide needs to be adjusted prior to every cutting operation to accommodate the height of the workpiece.

The upper blade guide should be set approx 3 mm above the workpiece.

Set the upper blade guide by turning the adjusting knob to the desired height and securing in position with the locking knob.

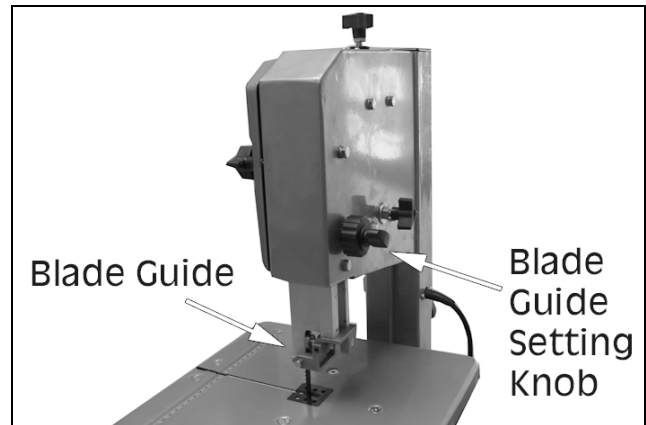

PREPARING FOR WORK

1. Press the green button to start the bandsaw.
2. Press the red button to stop the machine at any time.

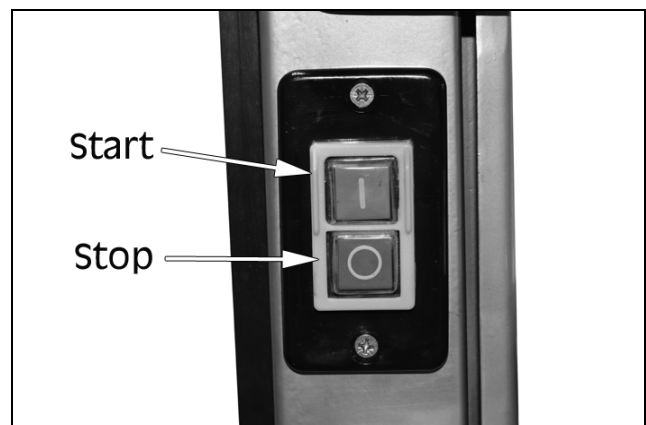

USING THE FENCE

The fence can be used on both sides of the blade.

1. Engage the fence with the table and move to the required position. The scale indicates the distance from the saw blade to the fence.
2. Ensure the fence is parallel to the blade groove.
3. Press down the locking lever to clamp the fence in position.

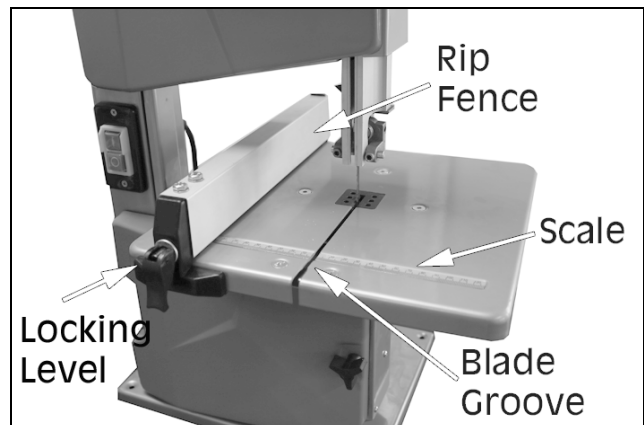

CONNECTING TO A DUST COLLECTOR

This bandsaw is fitted with a dust port for connection to a dust collector if available.

- The connector size is 36 mm i/d (40 mm o/d)

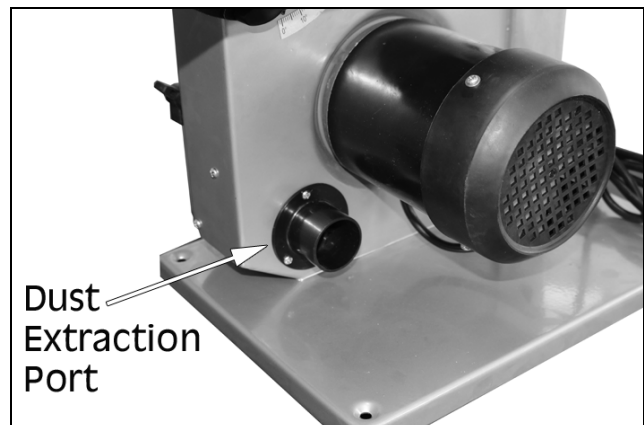

USING THE PUSH STICK

The push-stick serves as an extension of the operators hand as protection against accidentally touching the saw blade.

The push-stick should be used if the rip fence is close to the blade.

When not in use, the push-stick can be stored on the hook provided on the bandsaw frame.

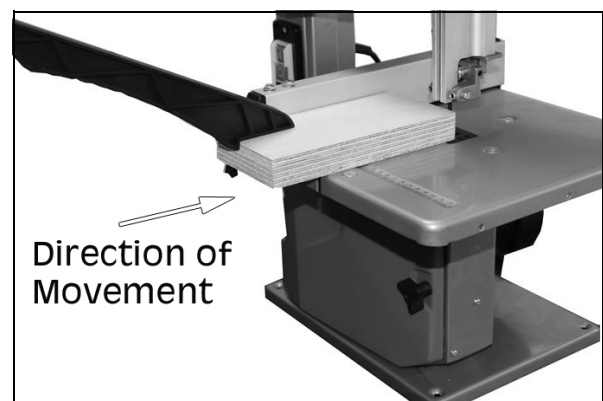

PRACTICAL OPERATION

Before commencing work, ensure the work area is clean and tidy and the machine table is clear of tools etc. Plan your work carefully and set the machine up accordingly before switching on.

- Check the blade is correctly tensioned before use (see page 12).
- Set the upper blade guide as close as practical to the workpiece. This provides the best safety for the operator and giving more accurate results and greater control.
- Adjust the height of the upper blade guide to achieve the best control. The guide should always be set to just clear the top of the workpiece by approximately 3mm.
- Switch on and allow the saw blade to reach full speed before proceeding.
- Use both hands to feed the workpiece. The work must be held flat on the table at all times to prevent binding with the blade. Use a steady, even pressure, just sufficient to keep the blade cutting.
- Always use the rip fence where possible to eliminate any sideways movement of the work. This is most important when the table is tilted at an angle.
- Remember that the blade removes material during the cut creating a gap called the 'kerf', which must be allowed for when cutting to exact sizes. Plan your cut so that the kerf is the scrap side of the line you wish to cut. Where necessary, allow a little more material for finishing.
- Always use a suitable holding device when cutting round or irregular shaped timber to prevent twisting of the work piece.

TYPES OF CUT

Several types of cut are possible with this saw i.e. rip cutting, cross cutting, freehand cutting.

RIP CUTTING

This term refers to cutting timber in the same direction as the grain, rather than across it. You can rip wood freehand to a drawn pencil line, but best results are obtained by using the rip fence.

If the table is set level, set the rip-fence to the left hand side of the blade, allowing you to use your right hand to hold the work firmly against the fence.

The scale on the table indicates the distance of the fence from the saw blade and can be used as shown on page 14.

When cutting a bevel rip, with the table tilted at any angle up to 45°, set the rip fence to the right hand side of the blade if the width of the workpiece allows it. With the fence on the 'downhill' side of the table, it will help support the workpiece.

The width of cut indicator (scale) on the guide rail may be used to set the rip fence to the required cutting position.

Long workpieces may require additional support in the form of blocks or rollers and may be pulled as well as pushed to pass them through the bandsaw.

CROSS CUTTING

This term refers to cutting timber at right angles to the grain. This type of cut can also be made freehand.

Make sure the work is held firmly against the table. Be careful to keep your fingers away from the blade, particularly at the end of the cut.

FREEHAND CUTTING

The ease with which many different and varied shapes can be cut is one of the most important features of the bandsaw.

When freehand cutting, always feed the work slowly so that the blade can follow the line you wish to cut. Make sure not to drag the work off line, forcing the blade sideways or twisting it.

In many cases, it is helpful to rough cut about 6mm away from the line. For difficult curves which may be too tight for the blade, make relief cuts at 90° to the face of the curve so that these scraps will fall away as the final radius is sawn.

Each blade has a minimum radius which it will be able to cut, dependant upon its width. The blade supplied is 6.35mm wide and able to cut as little as 62mm radius, beyond which the stress may cause it to break. If using a different blade, a bandsaw blade radius chart should be consulted.

MAINTENANCE



WARNING: ALWAYS SWITCH OFF THE MACHINE AND DISCONNECT FROM THE POWER SUPPLY BEFORE CARRYING OUT ANY CLEANING OR MAINTENANCE TASKS.

CLEANING

Accumulated dust and chips should be removed from inside the bandsaw frequently. Open the upper and lower covers, use a soft brush and/or vacuum cleaner to remove sawdust. If compressed air is used, ensure it is set to no more than 10 psi and ALWAYS wear eye protection.

At the end of every work session, clean sawdust away from the motor vents.

CHANGING THE SAW BLADE



WARNING: THE TEETH OF THE BLADE ARE SHARP. TAKE CARE WHEN HANDLING THE BLADE IN SITUATIONS SUCH AS UNPACKING, MOUNTING OR REPLACING.

1. Remove the U shaped blocker from the table.
2. Open the upper and lower covers.
3. Set the upper blade guide to its lowest position.
4. Loosen the blade tension setting knob until the saw blade has slackened.
5. Remove the saw blade from the machine.
6. Fit a fresh saw blade, passing it behind the side guard and aligning it with the upper and lower blade guides. Centre the blade on the rubber tyres of the wheels. Ensure the teeth are pointing downwards towards the table.
7. Tighten the blade tension setting knob.

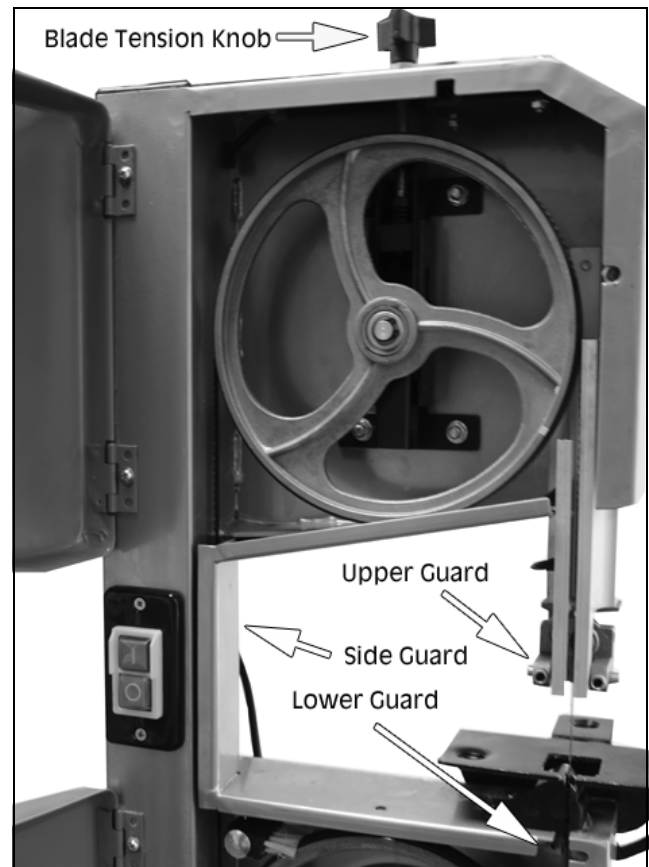

8. Set the blade tracking as described on page 11.
9. Close the upper & lower covers.
10. Adjust the blade tension as described on page 12.
11. Adjust the upper blade guide as described on pages 13.
12. Replace the U shaped blocker.

CHANGING THE WHEEL PULLEY TYRES

Eventually the rubber tyres on the bandsaw pulley wheels may wear due to the constant contact with the blade. Remove the saw blade as described on page 17, then lift the edge of the tyre with a small screwdriver and carefully work off the wheel. Ease on the new tyre, ensuring it sits evenly around the wheel.

We recommend that both tyres are changed at the same time.

BLADE GUIDES

Blade guides should be inspected regularly for wear or chipping, and replaced if necessary. See page 13 for blade guide adjustments.

BEARINGS

All bearings used in the construction of your bandsaw and its motor are sealed and lubricated for life.

STORAGE

Switch off the bandsaw and disconnect the power cable.

Cover the machine with a plastic bag and store it in a dry location and out of the reach of children.

OPTIONAL ACCESSORIES

REPLACEMENT BLADES

Suitable blades are available from your CLARKE stockist:

- 6tpi Bandsaw blade: Part No 6460058

DUST EXTRACTORS

A suitable dust extractor is available from your CLARKE stockist:

- CWVE1 Vacuum Dust Extractor: Part no 6471168

TROUBLESHOOTING

FAULT	CHECK	SOLUTION
The unit fails to operate	<ol style="list-style-type: none"> 1. Check for power failure if the unit is plugged in. 2. Check the switch is on and that the fuse is not blown. 3. Upper or lower door safety switch not engaged. 	<ol style="list-style-type: none"> 1. Plug the unit into the socket. 2. Replace fuse or switch on. 3. Check that upper/lower doors are fully closed making sure the safety switches are seated correctly
Blade breaks	<ol style="list-style-type: none"> 1. Faulty alignment (tracking) 2. Blade guides incorrectly adjusted. 3. Feeding the work too fast. 4. Forcing or twisting the blade around a tight radius. 5. Blade too tight. 6. Blunt teeth. 7. Blade is badly welded or brazed. 8. Wrong blade fitted. 9. Bandsaw left running when not in use. 	<ol style="list-style-type: none"> 1. Carry out tracking adjustments (p11). 2. Re-adjust blade guides (p13) 3. Lower the feed rate 4. For tight curves, make relief cuts fairly close together at 90° to the curve. A narrower blade will make a tighter curve. 5. Relieve blade tension 6. Renew blade 7. Renew blade 8. Fit only quality blades supplied by your CLARKE dealer. 9. Always switch machine off when not in use.
Noise or vibration	<ol style="list-style-type: none"> 1. Blade not correctly aligned. 2. Guides not securely set. 	<ol style="list-style-type: none"> 1. Carry out tracking adjustments (p11). 2. Tighten the locking knob. Check guides are correctly set.
Blade runs off the cutting line	<ol style="list-style-type: none"> 1. Blade guides incorrectly adjusted. 2. Blade tracking mal-adjusted 3. Blade tension too slack. 4. Wrong blade fitted (too thin). 	<ol style="list-style-type: none"> 1. Re-adjust blade guides (p13). 2. Carry out tracking adjustment (p11). 3. Re-tension blade. 4. Fit correct blade.

PARTS DIAGRAM

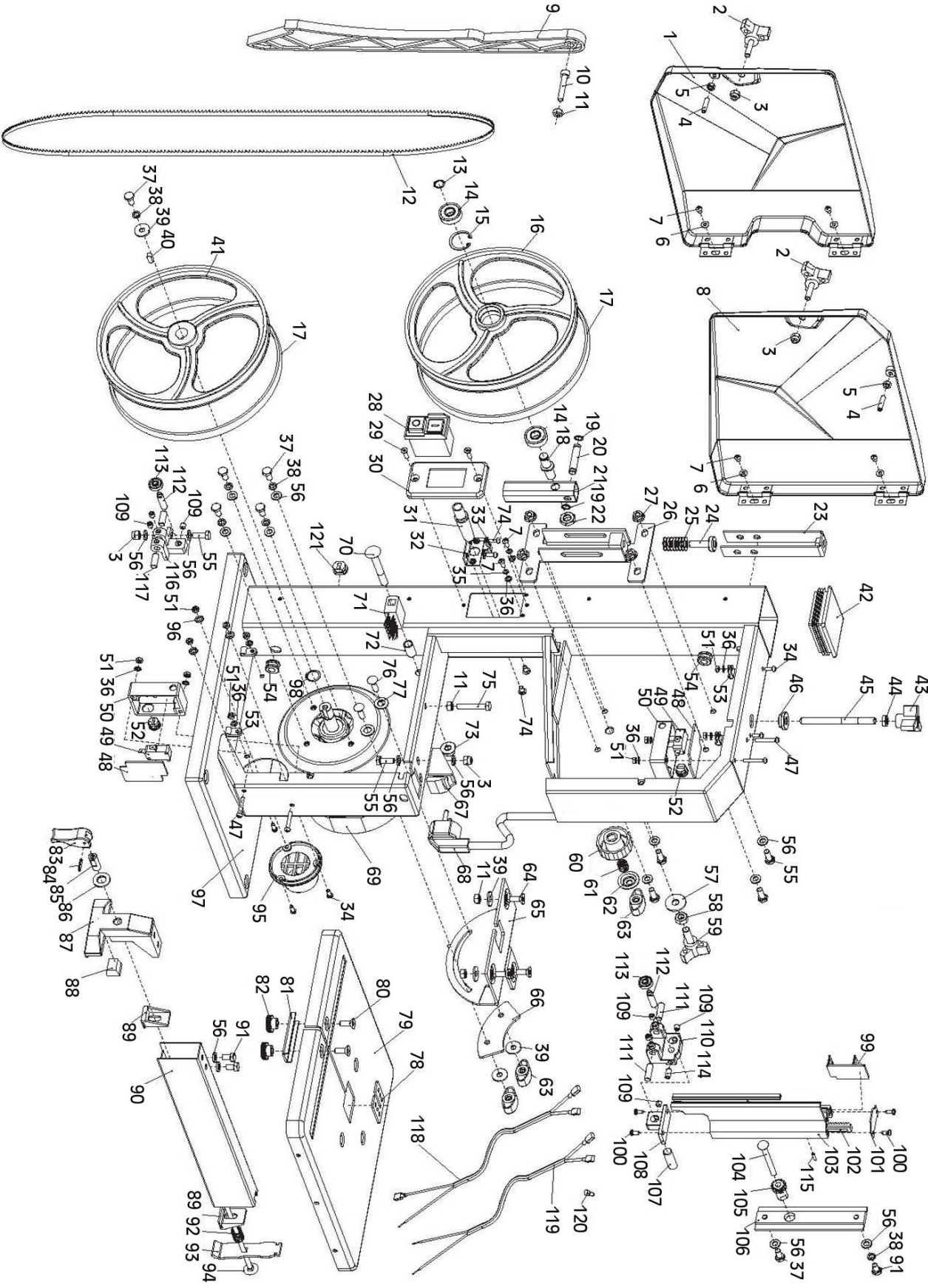



PARTS LIST



PART NO	DESCRIPTION	PART NO	DESCRIPTION
1	Lower Housing Door	35	Spring Washer 4
2	Door Locker M6x26	36	Lock Washer 4
3	Lock Nut M6	37	Bolt M6x12
4	Screw M5x25	38	Spring Washer 6
5	Nut M5	39	Big Flat Washer 6
6	Flat Washer 4	40	Key 5x14
7	Screw M4x8	41	Bandsaw Wheel - Lower
8	Lower Housing Door	42	Column Plug
9	Push Stick	43	Setting Knob for Blade Tension
10	Screw M6x35	44	Thin Nut M8
11	Nut M6	45	Adjusting Rod
12	Blade	46	Support Bushing
13	Circlip for Shaft 10	47	Screw M4x25
14	Bearing 6000-2Z	48	Microswitch Box Cover
15	Circlip for Hole	49	Microswitch
16	Bandsaw Wheel - Upper	50	Microswitch Box
17	Rubber Tyre	51	Nut M4
18	Upper Pulley Shaft	52	Power Cable Gland
19	Circlip for Shaft 8	53	Cable Clip
20	Horizontal Shaft	54	Hood
21	Upper Wheel Shaft Seat	55	Bolt M6x16
22	Thin Nut M10	56	Flat Washer 6
23	U Shaped Bracket	57	Big Flat Washer 8
24	Central Spindle	58	Nut M8
25	Wing Spring	59	Setting Knob - Blade Tracking
26	Guide Plate Assembly	60	Setting Knob - Blade Guard
27	Nut M6	61	Compression Spring
28	On/Off Switch	62	Wing Clip
29	Screw M4x12	63	Locking Knob
30	Switch Plate	64	Bolt M6x16
31	Cable Sheath	65	Bench Angle Gauge
32	Cable Fixing Plate	66	Lock Plate
33	Cable Pressing Plate	67	Lower Blade Guard
34	Screw M4x10	68	Plug & Power Cable

PARTS LIST

PART NO	DESCRIPTION	PART NO	DESCRIPTION
69	Motor	103	Upper Blade Guard
70	Bolt M8x65	104	Bolt M6x60
71	Brush	105	Gear
72	Bushing	106	Guide Block
73	Nut M8	107	Fixing Rod
74	Bolt M5x8	108	Upper Blade Guide Seat
75	Bolt M6x35	109	Screw M6x6
76	Bolt M6x20	110	Upper Blade Guide
77	Flat Washer 8	111	Upper Guide Pin
78	Table Insert	112	Bearing Shaft
79	Work Table	113	Bearing 625-2Z
80	Bolt M6x20	114	Screw M6x12
81	U Shaped Blocker	115	Pin 2.5x12
82	Knurled Nut	116	Lower Blade Guide
83	Rip Fence Locker	117	Lower Guide Pin
84	Pin 3x16	118	Upper Microswitch Cable
85	Connecting Bushing	119	Lower Microswitch Cable
86	Flat Washer 10	120	End Wire Connector
87	Rip Fence Holder	121	Cable Strain Relief Connector
88	Stop Block		
89	Clamping Block		
90	Rip Fence		
91	Bolt M6x10		
92	Rip Fence Spring		
93	Clamping Press Plate		
94	Clamping Screw Rod		
95	Suction Connection		
96	Lock Washer 5		
97	Machine Body Base		
98	Circlip 14		
99	Sliding Plate		
100	Screw ST3.5*9.5		
101	Dust Cap		
102	Rack		

DECLARATION OF CONFORMITY

	 Hemndill Street, Epping, Essex CM16 4LG
DECLARATION OF CONFORMITY This is an important document and should be retained.	
We hereby declare that this product(s) complies with the following statutory requirement(s): <i>Electromagnetic Compatibility Regulations 2016</i> <i>Supply of Machinery (Safety) Regulations 2008</i> <i>The Restriction of the Use of Certain Hazardous Substances in Electrical and Electronic Equipment Regulations 2012</i>	
The following standards have been applied to the product(s): EN 55014-1:2017+A11, EN 55014-2:2015, EN 61000-3-2:2019, EN 61000-3-3:2013+A1, EN 61029-1:2009+A11, EN 61029-2-5:2011+A11, EN ISO 12100:2010, IEC 62321-1:2013, IEC 62321-2:2013, IEC 62321-3-1:2013, IEC 62321-4:2013, IEC 62321-5:2013, IEC 62321-6:2015, IEC 62321-7-1:2015, IEC 62321-8, EN 62321:2009, ISO 17075:2017.	
The technical documentation required to demonstrate that the product(s) meet(s) the requirement(s) of the aforementioned legislation has been compiled and is available for inspection by the relevant enforcement authorities.	
The UKCA mark was first applied in: 2021	
Product Description:	195mm Band Saw
Model number(s):	CBS205
Serial / batch Number:	N/A
Date of issue:	06/12/2021
Signed:	 J.A. Clarke Director
CBS205 UKCA Clarke DOC 120621	
Page 1 of 1	

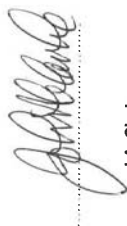
	 Fitzwilliam Hall, Fitzwilliam Place, Dublin 2
DECLARATION OF CONFORMITY This is an important document and should be retained.	
We hereby declare that this product(s) complies with the following directive(s): <i>2014/30/EU Electromagnetic Compatibility Directive.</i> <i>2006/42/EC Machinery Directive.</i> <i>2011/65/EU Restriction of Hazardous Substances (amended by (EU) 2015/863).</i>	
The following standards have been applied to the product(s): EN 55014-1:2017, EN 55014-2:2015, EN 61000-3-2:2014, EN 61000-3-3:2013, EN 61029-1:2009+A11, EN 61029-2-5:2011+A11, IEC 62321-1:2013, IEC 62321-2:2013, IEC 62321-3-1:2013, IEC 62321-4:2013, IEC 62321-5:2013, IEC 62321-6:2015, IEC 62321-7-1:2015, IEC 62321-8, EN 62321:2009, ISO 17075:2017.	
The technical documentation required to demonstrate that the product(s) meet(s) the requirement(s) of the aforementioned directive(s) has been compiled and is available for inspection by the relevant enforcement authorities.	
The CE mark was first applied in: 2020	
Product Description:	195mm Band Saw
Model number(s):	CBS205
Serial / batch Number:	N/A
Date of issue:	06/12/2021
Signed:	 J.A. Clarke Director
CBS205 CE Clarke DOC 120621	
Page 1 of 1	

A SELECTION FROM THE VAST RANGE OF

Clarke®

QUALITY PRODUCTS



AIR COMPRESSORS
From DIY to industrial, Plus air tools, spray guns and accessories.

GENERATORS
Prime duty or emergency standby for business, home and leisure.

POWER WASHERS
Hot and cold, electric and engine driven - we have what you need

WELDERS
Mig, Arc, Tig and Spot. From DIY to auto/industrial.

METALWORKING
Drills, grinders and saws for DIY and professional use.

WOODWORKING
Saws, sanders, lathes, mortisers and dust extraction.

HYDRAULICS
Cranes, body repair kits, transmission jacks for all types of workshop use.

WATER PUMPS
Submersible, electric and engine driven for DIY, agriculture and industry.

POWERTOOLS
Angle grinders, cordless drill sets, saws and sanders.

STARTERS/CHARGERS
All sizes for car and commercial use.



PARTS & SERVICE: 0208 988 7400

Parts Enquiries
Parts@clarkeinternational.com

Servicing & Technical Enquiries
Service@clarkeinternational.com

SALES: UK 01992 565333 or Export 00 44 (0)1992 565335

Clarke INTERNATIONAL Hemnall Street, Epping, Essex CM16 4LG
www.clarkeinternational.com